

TECHNICAL PASSPORT

Main technical characteristics

TECHNICAL PARAMETERS	MaksMaster-M G2 (E)	MaksMaster-M G2 (SC)
Supply voltage light (V):	12	
Light flow (lm/m):		
- cold white (C)	1220	
- warm white (W)	850	
Power consumption (W) max:		
- 3 LED	19	
- 6 LED	29	
Amperage (A) max:		
- 3 LED	1,6	
- 6 LED	2,4	
Ripple factor:	< 5%	
Dust and moisture protection:	IP20	
Electric shock protection class:	III	
Light distribution class:	direct light	
Storage temperature range:	from -30 to +60 (C°)	
Operating temperature range:	from +15 to +30 (C°)	
Net weight (kg):	1,3±0,1	1,6±0,1
Gross weight (kg):	1,9±0,15	2,2±0,15
Overall dimensions, mm. (LxW):	560x250	
Overall dimensions of packing mm. (LxWxH):	710x320x90	
Warranty period of operation (months):	6	

MANUAL

Before using the LED light, we recommend that you carefully study the "Manual", in order to avoid erroneous actions during the operation of the product by the consumer, which can lead to breakdown or damage to the product!

1. Purpose of light:

PDR LED light MaksMaster-M G2 refers to special-purpose luminaires and is intended for local illumination of the damaged area of car body parts, when carrying out repair and restoration work using the "Paintless Dent Repair" technology. It is used at specialized stations for body repair, car service stations, centers for training and advanced training of technicians in "Paintless Dent Repair", as well as in mobile body repair services.

ATTENTION!!! The light is not intended for use in a domestic environment, for lighting residential and office premises, workplaces, caring for plants and animals.

2. Product Description

The light body is made of durable embossed plastic, with stiffening ribs and ventilation holes. A C-shaped rubber profile is glued along the perimeter of the case, which protects the product from mechanical damage and prevents damage to the paintwork of the car in contact with the product. Inside the case there are LED strip, elements of the power supply system and electronic control. On the back of the body there is an ON / OFF rocker switch for the luminaire, as well as a plastic Loc-Line connector for attaching the body to a flexible DNE-Lock connection with clamp adjustment. Flexible connection allows you to fix and adjust the position of the light body at different angles to the plane of the car body parts. The product is attached to the surface using a vacuum suction cup (the manufacturer completes the lamp with a suction cup with a mechanical pump, the diameter of the bowl is 120 mm). To the light stand, the light is attached with a mounting assembly for mini light.

The light diffuser is made of shock-resistant lighting technology with a matte anti-reflective surface and a high degree of light transmission. Also on the diffuser there are control buttons and decorative elements.

The light is powered by a non-detachable cable 5 meters long; the end of the cable has a plug for a car cigarette lighter.

3. Main functions and operating modes

Combined control of LED strips (buttons 3,4,5) *

This function allows you to control two LED strips on one line with one button. A short or long press on the button turns on or off the LED strip according to the programmed "Priority mode".

* the combined control function is only available for light - 6 LED.

Programming function "Priority mode" (buttons 3 + 5 simultaneously) *

This function allows you to program the light operating mode: - priority of cold-white light or priority of warm-white light.

Indicator light parameters: **

- indicator 9 «C» – active operating mode cold-white priority;
- indicator 8 «W» – active operating mode warm-white priority.

To change the "Priority mode", you must simultaneously press and hold buttons 3 + 5 until the required mode is activated.

By default, the light is set to cool white priority mode.

* the combined control function is only available for light - 6 LED.

** "Priority mode" indicators are also control indicators of connection to the power supply.

«DIMMER» function (buttons 6 and 7)

This function provides a smooth or step-by-step adjustment of the brightness of the light. Button 6 increases the brightness "+", button 7 - decreases the "-". Long press on button 6 or 7 provides a smooth increase or decrease in the brightness of the light. Short presses of the buttons provide step-by-step adjustments.

Function of simultaneous switching off of all included LED strips (buttons 6 + 7 simultaneously)

This function is designed to quickly change the light operating mode and allows you to simultaneously turn off all connected LED strips. To do this, press and hold simultaneously the brightness adjustment buttons 6 7 until the LED strips turn off.

«MEMORY» function (buttons 1 and 2)

This function allows you to program various operating modes into the light memory. The user can independently program the most frequently used modes of operation or modes that are necessary for performing specific tasks.

Programming:

a) adjust the light in the first mode required for operation (number, color and brightness of LED strips). Then press and hold button 1 until one of the light indicators on the control panel 8 or 9 starts blinking: - MEMORY "I" setting completed. Adjust the second mode of operation of the light, and program it for the button 2 MEMORY "II". To reprogram the light operation modes, repeat the above actions for any of the two buttons of the "MEMORY" function.

Activating the required mode:

6) single short press on button 1 or 2.

Reset memory:

a) press and hold buttons 1 + 2 at the same time.

Remembering the last setting (automatically)

This function allows the electronic control unit to automatically remember the last operating mode of the light. After setting the operating mode of the light by the user (the number, color and brightness of the LED strips), the electronic control unit, after the expiration of the "standby mode" (5 seconds), remembers the current operating mode. When you turn off the light, or disconnect it from the power supply, and then turn it on again or connect to the power supply, the light will turn on in the same mode in which it was at the time of shutdown.

4. Ways to connect the light to the power supply

- the light is connected to the car's on-board network using a car cigarette lighter plug into the car's cigarette lighter socket. In this case, the positive potential of the power source "plus" should come to the central contact of the plug, and negative "minus" to the side contacts.

- to the ~ 110 / 220V AC mains, the lights must be connected through a ~ 110 / 220V – 12V step-down voltage converter equipped with a special car cigarette lighter socket for connecting to the light plug (not included in delivery).

- the light is connected to the storage battery using an adapter with alligator clips observing the polarity. The red clip is connected to the positive potential of the battery "plus", the black clip is connected to the negative "minus".

ATTENTION!!! The LED light is protected by the electronic control unit against erroneous polarity reversal.

The order of turning on the light

Set the mains switch, at the back of the light housing, to the "O" (off) position. Connect the plug of the light power cable to the socket of the car cigarette lighter, buck converter, or connect using an adapter with alligator clips to the battery terminals observing the polarity. Set the switch to the "I" (on) position. The light will turn on in the "Welcome" mode, the first time it is turned on, or in the mode in which it was at the time of the last shutdown by the user. Turn on the required number of LED strips and adjust the brightness. Change the "Priority mode" if necessary.

Light off order

Set the mains switch at the back of the light housing to the "O" position. Disconnect the power cable plug from the cigarette lighter socket or disconnect the adapter terminals from the battery.

ATTENTION!!! Do not leave the light connected to the power supply unattended or during long-term storage.

5. Care and maintenance

The light does not require special care, except for removing dust and dirt from the surface of the product. It is not recommended to wipe the diffuser with alcohol-containing solutions to avoid damaging the decor elements. To ensure proper operation of the vacuum suction cup, over a long period of operation, we recommend periodically cleaning the inner surfaces of the pump walls, as well as lubricating the rubber cuff on the pump rod. Change the dirty Suction Cup filter if necessary. Observe the position of the pump stem during operation. Pump up the pump until the indicator on the rod (red ring) disappears to prevent depressurization of the suction cup, which can lead to spontaneous fall of light. For comfortable work, check the condition of the clamps of the DNE-Lock flexible connections.

6. Additional Information

The product does not contain substances and materials harmful to health. There is no grounding and is not required.

After the end of the service life of the LED light, it must be disassembled into parts, sorted by type of material, and handed over to specialized organizations for the acceptance of raw materials for disposal.



DNEPRODENTTOOLS LLC

UA 49057, Ukraine, Dnipropetrovsk region, Dnipro,
Bogdan Khmelnitsky avenue 156

Tel: +38 (098) 406-60-50 (Viber, WhatsApp)

email: sales@dneprodent.com



Light control panel, model - 3 LED

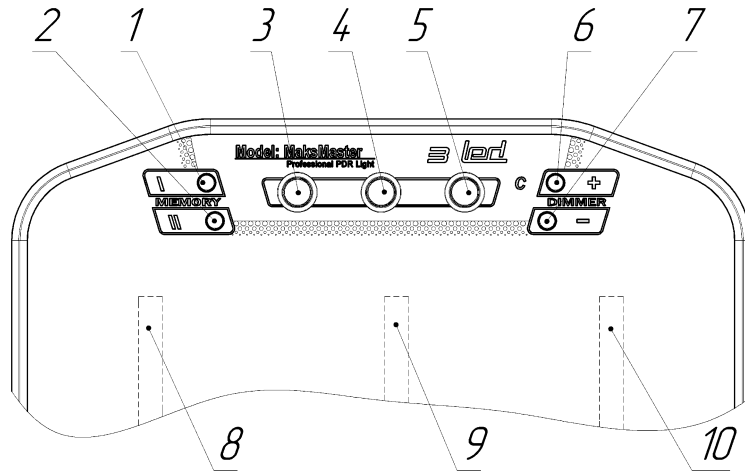

- 3,4,5 – LED strip control buttons
- 6,7 – brightness control buttons "DIMMER"
- 1,2 – «MEMORY» function control buttons
- 8,9,10 - LED strip
- «C» – network indicator

Light control panel, model - 6 LED

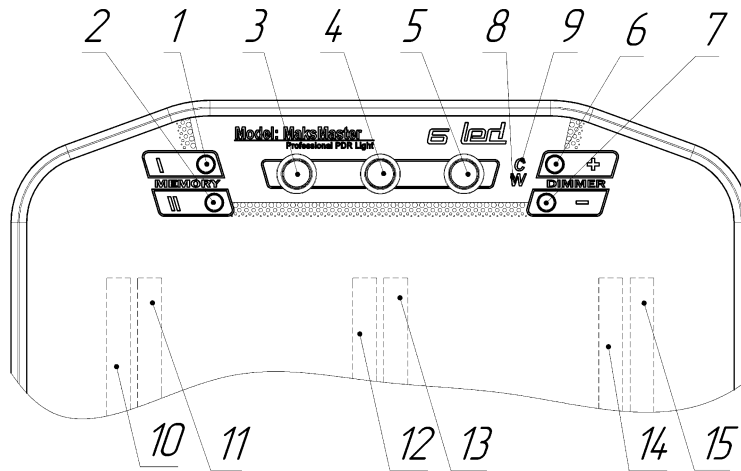

- 3,4,5 – LED strip control buttons
- 6,7 – brightness control buttons "DIMMER"
- 1,2 – «MEMORY» function control buttons
- 10-15 - LED strip
- 9 – "Priority mode" indicator cold-white glow "C" / network indicator
- 8 – "Priority mode" indicator warm-white glow "W" / network indicator

TABLE OF BASIC LIGHT CONTROL FUNCTIONS

Terms:

- Short press - single pressing of the button no more than 0.5 sec.
- Long press - pressing and holding the button for more than 0.5 sec.

Model – 3 LED		
Function	Actions	Expected result
Turning LED strips on/off	Short press, button 3	Turning the LED strip on/off 8
	Short press, button 4	Turning the LED strip on/off 9
	Short press, button 5	Turning the LED strip on/off 10
Brightness control "DIMMER"	Short press, button 6	Increasing brightness step by step
	Short press, button 7	Decrease brightness step by step
	Long press, button 6	Smooth increase in brightness
Simultaneous switching off of all included LED strips	Long press, button 7	Smooth decrease in brightness
	Simultaneous long press, buttons 6 + 7	All turn on LED strips are off
«MEMORY» function control	Long press, button 1	Indicator "C" is flashing MEMORY mode "I" programmed
	Long press, button 2	Indicator "C" is flashing MEMORY mode "II" programmed
	Short press, button 1	Activating the MEMORY "I" mode
	Short press, button 2	Activating the MEMORY "II" mode
	Simultaneous long press, buttons 1+2	Reset memory

Model – 6 LED		
Function	Actions	Expected result
Turning the LED strips on and off in the "Priority mode" cold-white	Short press, button 3	Turning the LED strip on/off 10
	Short press, button 4	Turning the LED strip on/off 12
	Short press, button 5	Turning the LED strip on/off 14
	Long press, button 3	Turning the LED strip on/off 11
	Long press, button 4	Turning the LED strip on/off 13
	Long press, button 5	Turning the LED strip on/off 15
Turning the LED strips on and off in the "Priority mode" warm-white	Short press, button 3	Turning the LED strip on/off 11
	Short press, button 4	Turning the LED strip on/off 13
	Short press, button 5	Turning the LED strip on/off 15
	Long press, button 3	Turning the LED strip on/off 10
	Long press, button 4	Turning the LED strip on/off 12
	Long press, button 5	Turning the LED strip on/off 14
Change "Priority mode" to warm-white	Simultaneous long press, buttons 3+5	Indicator 8 "W" lights up Mode activated
Change "Priority mode" to cold-white		Indicator "C" lights up Mode activated
Simultaneous switching off of all included LED strips	Simultaneous long press, buttons 6+7	All turn on LED strips are off
Brightness control "DIMMER"	Short press, button 6	Increasing brightness step by step
	Short press, button 7	Decrease brightness step by step
	Long press, button 6	Smooth increase in brightness
	Long press, button 7	Smooth decrease in brightness
	Long press, button 1	Indicator "C" or "W" is flashing MEMORY mode "I" programmed
«MEMORY» function control	Long press, button 2	Indicator "C" or "W" is flashing MEMORY mode "II" programmed
	Short press, button 1	Activating the MEMORY "I" mode
	Short press, button 2	Activating the MEMORY "II" mode
	Simultaneous long press, buttons 1+2	Reset memory